



Unbraked



In safe hands

Since 1958, people have put their trust in our trailers, just ask an owner - they're not difficult to find. As specialists in trailer design and engineering, we have continued to set the standard both in the UK and throughout much of Europe. We are an independent company with one focus: to build the best products on the market. More than 30,000 people choose our trailers each year - but we're not standing still. Our dedicated investment in new technologies and materials ensures that our products continue to exceed the expectations of our customers. We know that quality, strength, value and ease of maintenance are of vital importance to you. That's why we've made them the driving force behind everything we do.



Unbraked Trailers

The Ifor Williams unbraked trailer range provides a low-cost entry into towing for thousands of new users every year. Many owners have chosen these trailers for their ease of handling and towing plus their value for money. The extensive features add up to make an unbraked trailer the ideal choice for the smaller load.

Quality matters

There are many small lightweight trailers on the market today, but very few can boast the strength, durability and longevity provided by the Ifor Williams unbraked range. The multi purpose unbraked range has proven itself capable of withstanding the daily rigours of the professional user for many years.

Lightweight and manoeuvrable

All our unbraked trailers are designed around a strong, low maintenance rubber torsion suspension system and galvanized axle beam, providing many years of trouble free service. This exclusive axle has been designed to connect directly to the trailer body, creating a far lighter trailer. What we save on unladen weight you gain directly as payload.

Ease of coupling

The easy to use lockable coupling head with soft grab handle is a standard feature to the range - you'll find coupling up is effortless. For increased manoeuvrability when un-coupled a jockey wheel option is available.

Unrestricted

Unbraked trailers are not subject to any of the towing restrictions placed on drivers who have passed their test since 1997*, making them ideal starter trailers for new drivers. Always refer to the towing vehicle manufacturers handbook for maximum unbraked towing limit.

*Minimum requirement Licence category B.





P5 with ramp and optional weldmesh panelled side extensions

P5 Unbraked Trailer



P5 with fibreglass lockable hinged lid



P5 with tailboard and optional tarpaulin cover

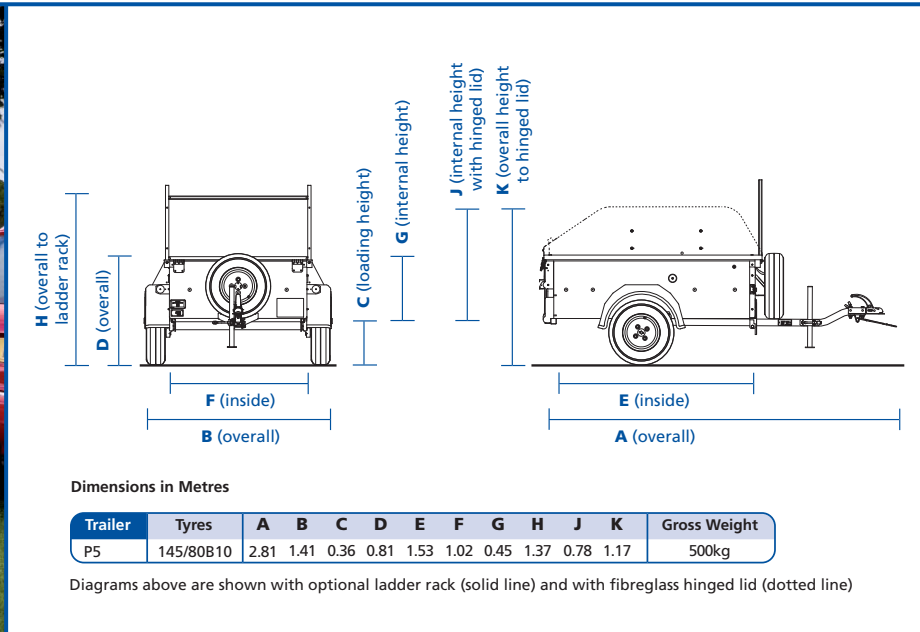

Dimensions in Metres

Trailer	Tyres	A	B	C	D	E	F	G	H	J	K	Gross Weight
P5	145/80B10	2.81	1.41	0.36	0.81	1.53	1.02	0.45	1.37	0.78	1.17	500kg

Diagrams above are shown with optional ladder rack (solid line) and with fibreglass hinged lid (dotted line)



P5 with ramp and optional weldmesh panelled side

The P5 is a compact and convenient trailer designed for domestic use and light commercial duties. Tougher than any other trailer of its size, the P5 is designed and built to professional standards. This trailer will provide many years of service and will outlast other less durable trailers available on the market.

The P5 offers an excellent strength to weight ratio with a maximum gross weight of 500kg and a payload starting at 359kg. With internal dimensions of 1.02m x 1.53m, the P5 is easily stored in your garage and will fit through narrower gateways that may prove problematic for wider trailers. The P5 can be towed with ease and its extra deep sides (0.45m Depth) ensures load volume is not compromised.

For regular trips to the tip or garden centre, the P5 is the ideal trailer for transporting heavy and awkward loads that your car cannot manage. From chippings, sand and gravel (up to 14 standard 25kg bags at a time), to concrete slabs, decking, plants and even domestic appliances, the P5 is an ideal introductory trailer that can be towed by most cars and vans.*

With a tailboard or ramp model available, you can select your P5 to suit the job or activity. A ramp option is ideal for loading wheeled equipment such as lawn mowers or wheel barrows.

Going on a camping trip? Why not cover your trailer load with a bespoke tarpaulin, a convenient and professional way of keeping your trailer contents under cover and out of sight. Alternatively, the Hardtop fibreglass lid is a great optional extra for the P5, offering security, increased volume and protection from the elements

Optional extras available on the P5 include front & rear prop stands, jockey wheel, ladder rack, mesh sides, tarpaulin, steel light guards, self fit lashing points and aluminium tread plate floor covering.

All P5 trailers are supplied with the following standard features:

- Spare wheel and carrier
- Lockable** 50mm ball coupling with soft grab handle
- Impact resistant plastic mudguards
- Wheelbrace

*Refer to towing vehicle manufacturers handbook for maximum unbraked towing limit.
**Requires padlock.



P6e livestock with 20.5 x 8 x 10 tyres (750kg)



P6e with optional ramp stock door, weldmesh panelled sides and 20.5 x 8 x 10 tyres (750kg)



P6e with optional weldmesh panelled sides and 20.5 x 8 x 10 tyres (750kg)



P6e with tailboard and 145/70R13 tyres (500kg)



P6e with optional weldmesh panelled sides, quad bike drawbar and 20.5 x 8 x 10 tyres (750kg)

P6e/P7e/P8e Unbraked Trailer

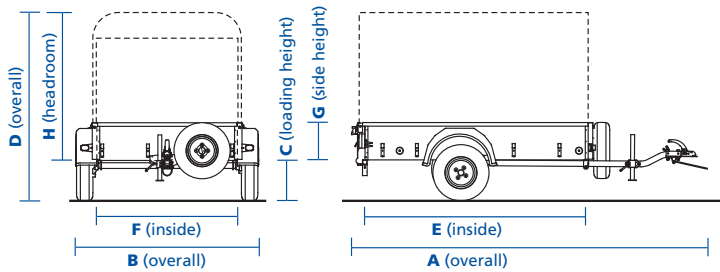

Dimensions in Metres

Trailer	Tyres	A	B	C	D	E	F	G	H	Gross Weight
P6e	145/80B10	2.95	1.65	0.40	1.58	1.98	1.21	0.31	1.12	500kg
P6e	20.5x8x10	2.95	1.72	0.41	1.59	1.98	1.21	0.31	1.12	750kg
P6e	145/70R13	2.95	1.63	0.40	1.58	1.98	1.21	0.31	1.12	500kg
P6e	145/70R13	2.95	1.63	0.41	1.59	1.98	1.21	0.31	1.12	750kg
P7e	20.5x8x10	3.18	1.72	0.41	1.59	2.21	1.21	0.31	1.12	750kg
P7e	145/70R13	3.18	1.63	0.40	1.58	2.21	1.21	0.31	1.12	500kg
P7e	145/70R13	3.18	1.63	0.41	1.59	2.21	1.21	0.31	1.12	750kg
P8e	20.5x8x10	3.53	1.96	0.41	*	2.51	1.45	0.31	*	750kg
P8e	145/70R13	3.53	1.87	0.41	*	2.51	1.45	0.31	*	750kg

* To follow See back cover for unladen weights

Larger, stronger and tougher than trailers typically sold at your local DIY or car parts superstore, the P6e, P7e and P8e are small trailers with big hearts. On the road they can be towed by a family car¹, off road they can even be towed by a quad bike.^{1,2} With ramp or tailboard versions, canopy and livestock options, gross weights of 500kg or 750kg on most models and a range of optional accessories, the P6e, P7e and P8e cater for most domestic, light commercial and general farmyard duties.

The axle, drawbar and body panels of these trailers are constructed from hot-dipped galvanised steel. The floor is 18mm thick high density plywood with a tough, water-proof resin coating on both sides. A factory fitted option of 2mm aluminium treadplate overlay is available. The loading ramp is panelled in 2mm thick slip resistant aluminium tread plate.

The P8e offers sufficient space to conveniently carry most standard building sheets/ plasterboard (typical size of 2.4m x 1.2m). In addition it carries most 'side by side' ATVs and many lawnmowers.

Optional extras for all three models include rear prop stands for additional stability when loading, jockey wheel, lashing points for securing loads, aluminium tread plate floor covering, ladder rack and welded mesh side panels – invaluable when carrying large bulky objects such as hedge cuttings, waste paper and fire-wood.

Standard features include:

- Spare Wheel and carrier
- Lockable* 50mm ball coupling with soft grab handles
- Adjustable front prop stand
- Rope hooks Impact resistant plastic mudguards
- Strong steel framed ramp or tailboard
- Wheelbrace (also fits mesh side clamps)



P7e with ramp, optional rear prop stands and 20.5 x 8 x 10 (750kg)

P6e with tailboard and 145/70R13 tyres (500kg)

¹ Refer to towing vehicle manufacturers handbook for maximum unbraked towing limit.

² If fitted with optional Quad Bike drawbar.

*Requires padlock

Unbraked

- Delivery Charge to UK Mainland Distributor
- Trailer with Tailboard
- Trailer with Ramp*
- Fibreglass Lockable Hinged Lid (Complete with Gas Struts)
- Trailer with Canopy (Ramp)*†
- Trailer with Canopy (Meshgate)†
- Trailer with Canopy (Aluminium Door)†
- Trailer with Livestock Kit (Ramp)*†
- Aluminium Treadplate Floor Covering
- Prop Stands (Pair)
- Jockey Wheel (Front Prop Stand Included)
- Lashing Points (Pair) Self Fit Supplied Loose
- Weldmesh Panelled Side Extensions (Ramp Trailer)
- Weldmesh Panelled Side Extensions (Tailboard Trailer)
- Ladder Rack
- ATV Drawbar - Self Fit Supplied Loose (Steel Tube Only)
- Light Guards (Pair)
- Tarpaulin (Blue)
- Livestock Cross Division

	Maximum Gross Weight	Tyres																			
P5	500kg	145/80B10	£60	£530	£580	£290**	-	-	-	-	£70	£40	£25	£10	£150	£165	£40	-	£30	£45	-
P6e	500kg	145/80B10	£60	£555	£610	-	£950	£930	£1,010	£1,075	£110	£40	£25	£10	£195	£235	£45	£40	£30	£55	£65
P6e	750kg	20.5x8x10	£60	£610	£670	-	£1,010	£990	£1,070	£1,135	£110	£40	£25	£10	£195	£235	£45	£40	£30	£55	£65
P6e	500kg	145/70R13	£60	£580	£640	-	£980	£955	£1,035	£1,105	£110	£40	£25	£10	£195	£235	£45	£40	£30	£55	£65
P6e	750kg	145/70R13	£60	£600	£660	-	£1,000	£975	£1,055	£1,125	£110	£40	£25	£10	£195	£235	£45	£40	£30	£55	£65
P7e	750kg	20.5x8x10	£60	£675	£730	-	£1,085	£1,060	£1,145	£1,210	£120	£40	£25	£10	£205	£245	£45	£40	£30	£60	£65
P7e	500kg	145/70R13	£60	£640	£695	-	£1,050	£1,030	£1,115	£1,180	£120	£40	£25	£10	£205	£245	£45	£40	£30	£60	£65
P7e	750kg	145/70R13	£60	£660	£720	-	£1,075	£1,050	£1,135	£1,200	£120	£40	£25	£10	£205	£245	£45	£40	£30	£60	£65
P8e	750kg	20.5x8x10	£60	£810	£870	-	£1,255	£1,235	£1,320	-	£160	£40	£25	£10	£245	£290	£50	-	£30	-	-
P8e	750kg	145/70R13	£60	£800	£860	-	£1,245	£1,225	£1,310	-	£160	£40	£25	£10	£245	£290	£50	-	£30	-	-

Unladen weights

	Maximum Gross Weight	Tyres							
P5	500kg	145/80B10	141kg	150kg	162kg	-	-	-	-
P6e	500kg	145/80B10	156kg	163kg	-	181kg	182kg	191kg	230kg
P6e	750kg	20.5 x 8 x 10	172kg	179kg	-	197kg	198kg	207kg	246kg
P6e	500kg	145/70R13	156kg	163kg	-	181kg	182kg	191kg	230kg
P6e	750kg	145/70R13	172kg	179kg	-	197kg	198kg	207kg	246kg
P7e	750kg	20.5 x 8 x 10	193kg	200kg	-	221kg	220kg	224kg	267kg
P7e	500kg	145/70R13	177kg	184kg	-	205kg	204kg	208kg	251kg
P7e	750kg	145/70R13	193kg	200kg	-	221kg	220kg	224kg	267kg
P8e	750kg	145/70R13	218kg	225kg	-	***	***	***	-
P8e	750kg	20.5 x 8 x 10	218kg	225kg	-	***	***	***	-

*P6e & P7e trailers with a ramp are available with a ramp Stock Door for an additional £60. This is a factory fit only option and must be specified at the time of order.

**Suitable for Tailboard version of P5 only.

†Trailers fitted with canopies are charged an additional £15 delivery.

All trailer weights are unladen and exclude any optional extras

Optional accessories have been priced as factory fit items, ordered with the trailer. If ordered at a later date, your distributor may need to fit the items, which could result in fitting charges being incurred.



Ifor Williams Trailers Ltd
 Cynwyd, Corwen, Denbighshire LL21 0LB UK
 Telephone +44 (0)1490 412527
 Facsimile +44 (0)1490 413216

For further information visit our comprehensive website
www.iwt.co.uk

Product design, descriptions, colours, specifications etc. correct at time of going to press. We constantly strive to improve our products, and from time to time this may result in changes to our range or to individual models. Please check that design, description, colours, specifications described in this brochure are still valid at the time of placing an order.

Our distributors have extensive product knowledge and will be pleased to offer assistance in the selection of your trailer.

© Ifor Williams Trailers Ltd 2011. All rights reserved.

No part of this publication may be reproduced in any form or by any means, without the prior written permission of Ifor Williams Trailers Ltd.

We would like to thank the following for their assistance in the photography of this brochure: The National White Water Centre, Bala. North Wales ATV Centre, Denbigh. Dane Audi, Chester.

Prices are ex-works and are subject to delivery charges and the VAT rate applicable at the date of supply. Dimensions and weights are given as a guide only. We reserve the right to alter specifications without notice.

Distributed throughout the UK & Europe.



The BV64e unbraked mini box van, our smallest box van in the range. Further details are available in our Box Van brochure.



TRAILERS INCLUDE A SPARE WHEEL FITTED AS STANDARD